

standard and specials

# chisels

for woodworking

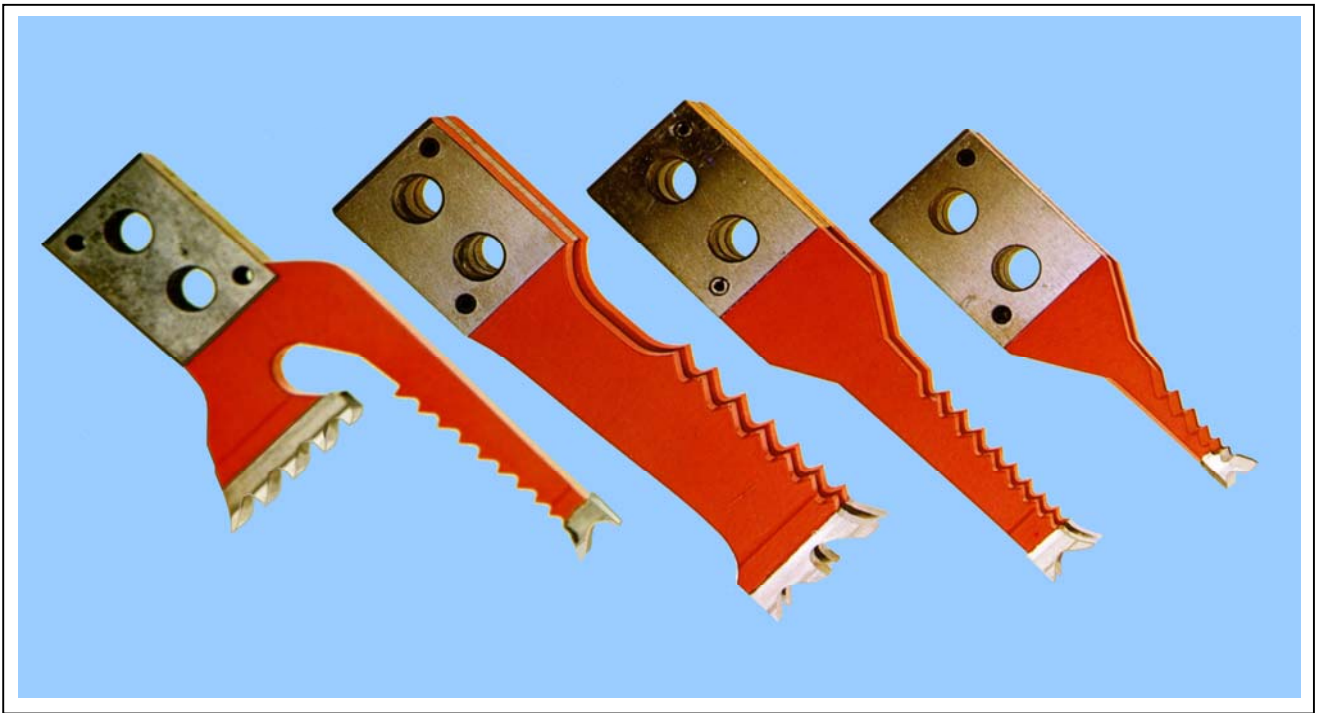

**1.1.09 Pricelist**

  
**Utensilegno**



## Presentation

Utensilegno, founded in 1945, is mainly equipped for series production of woodworking tools: high performance mortising chains and chisels.

Utensilegno Chisels, as described in this price-list, are produced using special steels, specifically studied and calibrated to get an optimal cutting result and a long life time.

## General description

Utensilegno Chisels consist of a thermally treated HSS body on which a cutting part is installed and is realized by an integrated teeth insert. The special steel used here ensures high quality, precision, as well as a minimized risk of breaking the tools.

The production is performed by a modern automatic process during which the tools are carefully controlled and tested before releasing them on the market, in order to offer an economical and constant solution to the customer requests.

Utensilegno Chisels are available for any kind of attachment shape, with different profiles, such as single chisels or multiple ones.

## The mortise

It is possible to get different mortise shapes with the Utensilegno Chisels: standard, double ones, trapezoidal, with or without heel, as shown in the figure of this page and the next one.

Each standard mortise is defined by its three dimensions: Width (**W**), Length (**L**) and Depth (**D**).

Tandem mortises are further defined by the distances left between the mortises.

The trapezoidal mortises are characterized by the specific trapezoidal shape with its angles and sizes depending on the customer needs.

The mortise chisels with heel are defined by the standard mortise dimensions completed by the length (**LH**) and the depth (**DH**) of the heel, as shown in the figure to the side.

The possible dimensions of the mortises that can be obtained are printed on each chisel. For instance 50/60-10-80 means that this chisel enables you to get a 10 mm wide, 50 to 60 mm length and 80 mm deep mortise.

Please notice that the mortise size can never be less than the printed dimension on the chisel. Furthermore the mortise shall have a maximum depth corresponding to one and a half its length.

Utensilegno Chisels can be used both horizontally and vertically.

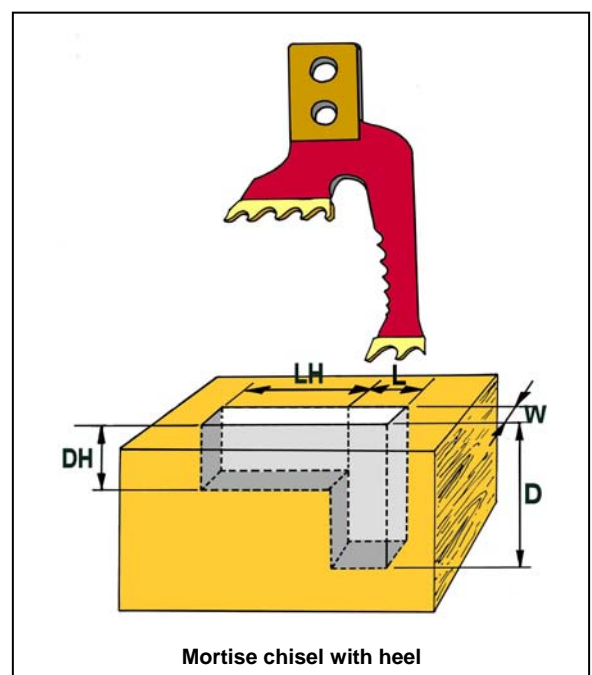
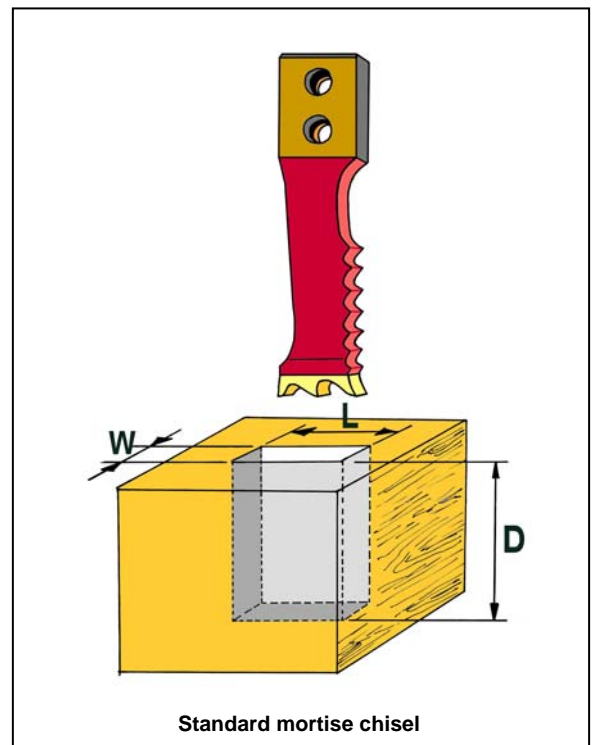

### MAINTENANCE

Sharpening the chisels is a very important task.

We highly recommend to let perform this work only by skilled sharpening centers which know this particular kind of tools, as a bad sharpening work can cause a breaking of the tool.

In case of breaking we can rebuild the teeth insert.

### ORDER INSTRUCTIONS

To order mortise chisels please provide the following information:

- the *brand of the chisels machine*, as each manufacturer has got its own fixing system and shapes;
- the *mortise dimensions*: Width (W, corresponding to the thickness or width of the chisel), length (L), cut depth (B) and the total length of the chisel (C);
- whether it shall be used horizontally or vertically;
- in case of tandem chisels, or trapezoidal ones, please indicate which *side* is "right or left" (referred to the cutting direction) and the *distance between the mortises*;
- if the chisel has to be with heel, it is necessary to indicate also the length (LH) and the depth (DH) of the heel.

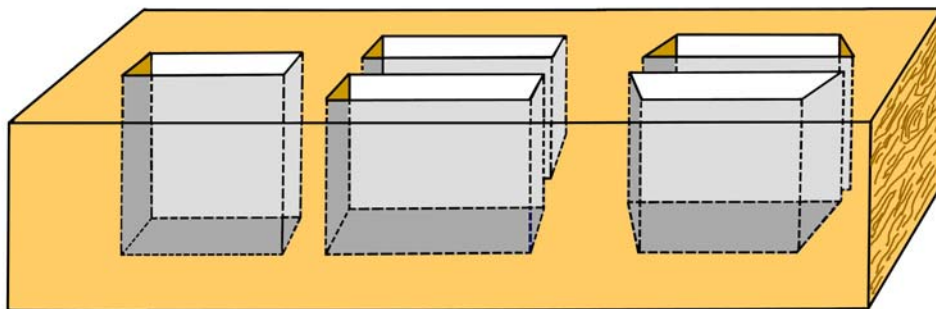
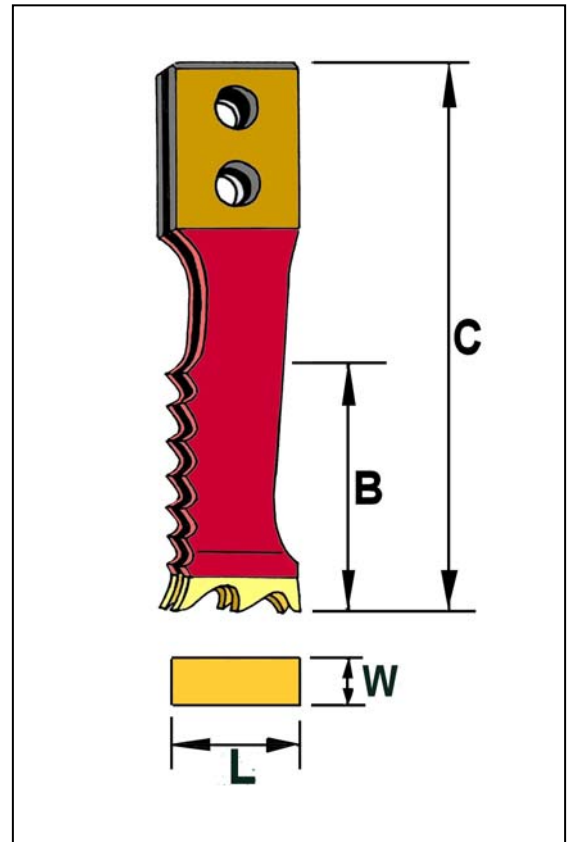

Mortises without heel: standard, tandem and trapezoidals

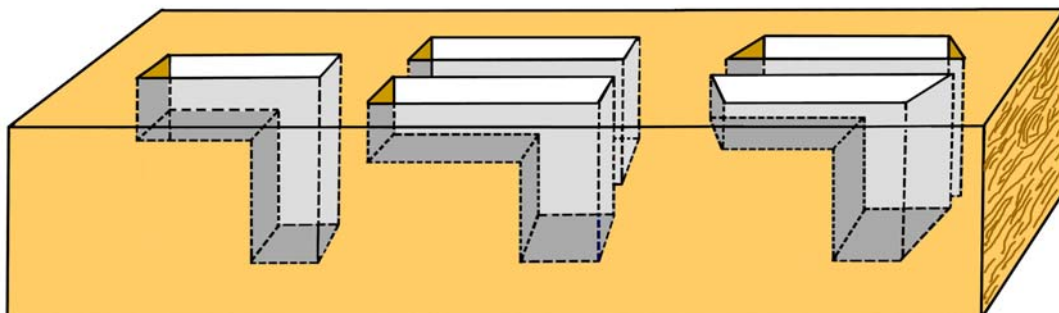







Mortises with heel: standard, tandem and trapezoidals



## MORTISE CHISELS WITHOUT HEEL

FOR VERTICAL AND HORIZONTAL CHISEL MACHINES OF ALL MAKE

FOR MORTISES from 6 to 20x25/75x50/100 mm, CHISELS WITH 2 and 3 TEETH



Toothing cut	Thickness LA mm	Mortise LU min -max	Depth P mm	STRAIGHT		INCLINED		
				SINGLE	COUPLE	SINGLE	COUPLE	
 	6	25/35	50/60	€ 280,00	515,20	342,40	577,60	
	7							
	8							
	9	or		30/40	€ 304,00	531,20	350,40	593,60
	10							
	11							
	12							
	13							
	14							
	15	or		35/45	€ 312,00	539,20	364,80	588,80
	16							
	17							
	18							
19								
20								
 	6	40/50	70/80	€ 318,40	558,40	368,00	608,00	
	7							
	8							
	9	or		45/55	€ 326,40	592,00	376,00	638,40
	10							
	11							
	12							
	13							
	14							
	15	or		50/60	€ 342,40	622,40	388,80	652,80
	16							
	17							
	18							
19								
20								
 	6	55/65	80/100	€ 350,40	638,40	398,40	664,00	
	7							
	8							
	9	or		60/70	€ 358,40	649,60	409,60	670,40
	10							
	11							
	12							
	13							
	14							
	15	or		65/75	€ 371,20	662,40	424,00	673,60
	16							
	17							
	18							
19								
20								



## MORTISE CHISELS WITHOUT HEEL

FOR VERTICAL AND HORIZONTAL CHISEL MACHINES OF ALL MAKE

FOR MORTISES from 6 to 20x70/120x90/120 mm, CHISELS WITH 4 and 5 TEETH

Toothing cut	Thickness LA mm	Mortise LU min -max	Depth P mm	STRAIGHT		INCLINED	
				SINGLE	COUPLE	SINGLE	COUPLE
	6	70/80	90/110	€ 379,20	668,80	430,40	686,40
	7						
	8						
	9	or		€ 395,20	673,60	438,40	699,20
	10						
	11						
	12	75/85		€ 403,20	684,80	446,40	712,00
	13						
	14						
	15	or		€ 424,00	713,60	456,00	729,60
	16						
	17						
18	80/90	€ 435,20	729,60	486,40	755,20		
19							
20							
	6	85/95	100/120	€ 449,60	744,00	502,40	772,80
	7						
	8						
	9	or		€ 456,00	761,60	515,20	784,00
	10						
	11						
	12	90/100		€ 470,40	790,40	531,20	806,40
	13						
	14						
	15	or		€ 486,40	819,20	548,80	851,20
	16						
	17						
18	95/105	€ 486,40	819,20	548,80	851,20		
19							
20							
	6	100/110	100/120	€ 486,40	819,20	548,80	851,20
	7						
	8						
	9	or		€ 470,40	790,40	531,20	806,40
	10						
	11						
	12	105/115		€ 486,40	819,20	548,80	851,20
	13						
	14						
	15	or		€ 486,40	819,20	548,80	851,20
	16						
	17						
18	110/120	€ 486,40	819,20	548,80	851,20		
19							
20							

## MORTISE CHISELS FOR LOCKS

Mortise sizes mm	10 a 20	130	120	€ 579,20
	10 a 20	180	120	€ 640,00

**MORTISE CHISELS WITH HEEL**

FOR VERTICAL AND HORIZONTAL CHISEL MACHINES OF ALL MAKE

FOR MORTISES from 6 to 12x30/80 mm, CHISELS WITH 2, 3 and 4 TEETH

Toothing cut	Thickness LA mm	Mortise L min -max	Heel LC mm	STRAIGHT		INCLINED		
				SINGLE	COUPLE	SINGLE	COUPLE	
	6	30/40	50	€ 424	776	486,4	836,8	
	7							
	8							
	9							
	10							
	11							
	12	or	40/50	70	€ 456	785,6	507,2	848
	6							
	7							
	8							
	9							
	10							
	11	50/60	65	€ 465,6	806,4	516,8	857,6	
	12							
	6							
	7							
	8							
	9							
	10	or	60/70	80	€ 486,4	827,2	537,6	868,8
	11							
	12							
	6							
	7							
	8							
9	70/80	65	€ 528	868,8	558,4	889,6		
10								
11								
12								
6								
7								
8	or	70/80	80	€ 548,8	910,4	579,2	931,2	
9								
10								
11								
12								

**MORTISE CHISELS WITH HEEL**

FOR VERTICAL AND HORIZONTAL CHISEL MACHINES OF ALL MAKE

FOR MORTISES from 6 to 12x80/100 mm, CHISELS WITH 4 and 5 TEETH

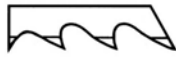
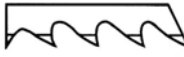
Toothing cut	Thickness LA mm	Mortise L min -max	Heel LC mm	STRAIGHT		INCLINED		
				SINGLE	COUPLE	SINGLE	COUPLE	
	6	80/90	65	€ 579,20	931,20	609,60	950,40	
	7							
	8							
	9							
	10							
	11							
	12							
	6							
	7							
	8							
	9							
	10							
	11							
	12							
		6	90/100	65	€ 641,60	971,20	672,00	992,00
		7						
		8						
		9						
		10						
		11						
		12						
		6						
		7						
		8						
9								
10								
11								
12								
		6	100/110	65	€ 723,20	1.012,80	755,20	1.054,40
		7						
		8						
		9						
		10						
		11						
		12						
		6						
		7						
		8						
	9							
	10							
	11							
	12							

## CHISEL ATTACHMENT FOR NARROW MORTISES

FOR MORTISING MACHINES HAVING AN "E" CENTRES OF 150 mm

FOR MORTISES FROM 1 TO 5x22x55 mm, CHISELS WITH 1 AND 3 HOLES

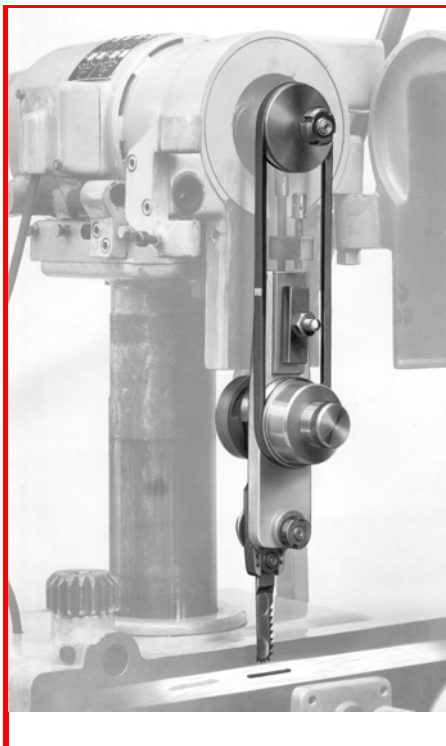

Utensilegno produces an attachment with which it is possible to resolve the problem of very narrow mortises which are impossible to form with normal mortising chains. It is easy to apply to the chain mortising machine, like a normal set. Made of carefully selected tempered steel, it consists of:

- a main body applied to the mortising machine in place of the normal guide bar;
- a pulley that is screwed onto the motor shaft of the mortising machine in place of the sprocket;
- a belt that transmits the rotary movement necessary to make the mortise.

The length of the belt is calculated for attachment to mortising machines with a guide-sprocket centres of 150 mm.

The attachment for narrow mortises is more precise than similar portable appliances, as it is fitted to heavy duty stationary mortising machines.

Small chisels are applied to the attachment, with which it is possible to make mortises from 1 to 5 mm wide.

The minimum length that can be obtained is 22 mm and the depth is 55 mm.

### UNIT NET PRICES

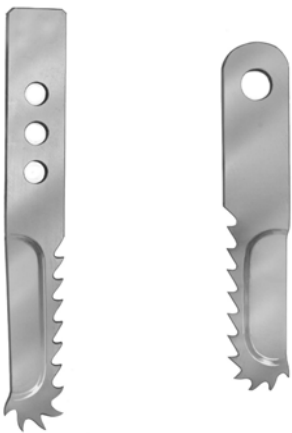
Chisel attachment for narrow mortises without chisel		€	480,00
 <p>Chisel Tatri model    Chisel Utensilegno model</p>	Chisel 1 mm thicknes	€	22,00
	Chisel 1,25 mm thicknes	€	22,00
	Chisel 1,50 mm thicknes	€	22,00
	Chisel 1,75 mm thicknes	€	22,00
	Chisel 2 mm thicknes	€	22,00
	Chisel 2,25 mm thicknes	€	22,00
	Chisel 2,50 mm thicknes	€	22,00
	Chisel 2,75 mm thicknes	€	22,00
	Chisel 3 mm thicknes	€	22,00
	Chisel 3,25 mm thicknes	€	22,00
	Chisel 3,50 mm thicknes	€	24,00
	Chisel 4 mm thicknes	€	24,00
	Chisel 4,50 mm thicknes	€	24,00
	Chisel 5 mm thicknes	€	24,00